



7th All India RPS



OL  **MPIAD**

Online & Offline Mega Event

QUESTION PAPER

M.M:60

Time: 60 minutes

OFFLINE EXAMINATION (PHASE-II)

CLASS - X

Name: _____ Reg. No. _____ Mobile No. _____

General Instructions:

1. Duration of the examination is 60 minutes. Question Paper contains 60 questions with maximum 60 marks.
2. There will be negative marking in Phase – II, i.e. $\frac{1}{4}$ mark will be deducted for each incorrect answer.
3. Use of gadgets is not allowed.
4. Students must abide by the instructions issued during the examination by the invigilator or the centre incharge.
5. Before attempting the question paper ensure that it contains all pages & no question is missing.
6. Immediately fill the particulars on this page of the test booklet and OMR with BLACK ballpoint pen only. Use of pencil is strictly prohibited.
7. Fill and darken the bubbles completely. Do not put a tick or a cross.
8. Half -filled or over-filled bubbles will not be read by the software & liable to be rejected.

Correct Method



Student's Signature

Wrong Method



Invigilator's Signature

SPACE FOR ROUGH WORK

English (10 Marks)

Q1. India is one of those few countries which _____ a steady growth rate of their national product over more than three decades.

- (A) has maintained (B) was maintained
(C) have maintained (D) did maintained

Q2. What is the meaning of the given Idiom / Phrase?

‘Hook, line and sinker’

- (A) Elaborately (B) With full preparation
(C) Judiciously (D) Completely

Q3. What does the idiom ‘Be-all and end-all’ mean?

- (A) From beginning to end (B) That which begins well.
(C) That which ends well (D) The whole and sole.

Q4. Choose the correct word to fill in the blank:

A variety of subjects _____ taught in the school.

- (A) were (B) is (C) are (D) did

Q5. Change the following sentence into Indirect Speech:

The teacher said to the student, “How can you prove that the earth is round?”

- (A) The teacher asked the student how could he prove that the earth is round.
(B) The teacher asked the student how he could prove that the earth is round.
(C) The teacher asked the student how he could prove that the earth was round.
(D) The teacher asked the student how he could proved that the earth is round.

Q6. Out of the four alternatives, choose the one which can be substituted for the given sentence:

‘Vehicle to carry dead bodies.’

- (A) Gratis (B) Hearse (C) Etymon (D) Stoic

Q7. The Passive Voice of – ‘God helps those who help themselves.’ is:

- (A) Those who help themselves will be helped by God.
(B) Those who help themselves are helped by God.
(C) They are helped by God who have helped themselves.

(D) Those who are helped themselves will be helped by God.

Q8. Complete the following sentence with the correct option:

Lydia has _____ a large sum of money to build a decent house.

- (A) put by (B) put in (C) put off (D) put with

Q9. Which Figure of Speech is used in the given sentence?

‘A boy who eats dates makes good use of his time.’

- (A) Personification (B) Transferred Epithet
(C) Oxymoron (D) Pun

Q10. Read the given sentence and find out the error part:

Being often ill(A)/ and frequently absent(B)/ she had no opportunity to complete her work(C)/or do much of it in toto. (D)

Mathematics (20 Marks)

Q11. If $x = \frac{a-b}{a+b}$, $y = \frac{b-c}{b+c}$, $z = \frac{c-a}{c+a}$, then what is the value of $\frac{1+x}{1-x} \cdot \frac{1+y}{1-y} \cdot \frac{1+z}{1-z}$?

- (A) 1 (B) 0 (C) 2 (D) 3

Q12. If $x^2 - 4x + 1 = 0$, then what is the value of $x^3 + \frac{1}{x^3}$?

- (A) 53 (B) 54 (C) 52 (D) 51

Q13. If $a + b + c = 0$, then what is the value of $\frac{a^2+b^2+c^2}{(a-b)^2+(b-c)^2+(c-a)^2}$?

- (A) 1 (B) 3 (C) $\frac{1}{3}$ (D) 0

Q14. If $3^x + 27(3^{-x}) = 12$, then what is the value of x ?

- (A) 1 or 3 (B) 1 or 2 (C) 2 or 3 (D) 1 or 3

Q15. What is the value of a for which the equation $2x^2 + 2\sqrt{6}x + a = 0$ has equal roots?

- (A) 3 (B) 2 (C) 1 (D) 4

Q16. Find the value of $\sqrt{6 + \sqrt{6 + \sqrt{6 + \dots \infty}}}$.

- (A) -4 (B) 2 (C) 3 (D) 6

Q17. If the roots of $x^3 - 12x^2 + 12x - 28 = 0$ are in A.P, their common difference is:

- (A) ± 3 (B) ± 2 (C) ± 1 (D) None of these

Q18. If the medians of two equilateral triangles are in the ratio 3 : 2, then what is the ratio of their sides?

- (A) 1 : 1 (B) 2 : 3 (C) 3 : 2 (D) $\sqrt{3} : \sqrt{2}$

Q19. If AD is the median of $\triangle ABC$, then:

- (A) $AB^2 + AC^2 = 2AD^2 + 2BD^2$ (B) $AB^2 + AC^2 = 2AD^2 + BD^2$
 (C) $AB^2 + AC^2 = AD^2 + BD^2$ (D) $AB^2 + AC^2 = AD^2 + 2BD^2$

Q20. Let ABC be a triangle of area 16 cm^2 . XY is drawn parallel to BC dividing AB in the ratio 3 : 5. If BY is joined, then the area of triangle BXY is:

- (A) 3.5 cm^2 (B) 3.7 cm^2 (C) 3.75 cm^2 (D) 4.0 cm^2

Q21. What is the value of $\cos 480^\circ \sin 150^\circ + \sin 600^\circ \cos 390^\circ$?

- (A) -1 (B) -2 (C) -3 (D) None of these

Q22. If A lies in the third quadrant and $3 \tan A - 4 = 0$, then what is the value of $5 \sin 2A + 3 \sin A + 4 \cos A$?

- (A) 1 (B) 0 (C) 3 (D) 2

Q23. If $\sin x + \operatorname{cosec} x = 2$, then $\sin^n x + \operatorname{cosec}^n x$ is equal to:

- (A) 2 (B) 2^n (C) 2^{n-1} (D) 2^{n-2}

Q24. Determine the ratio in which $2x + 3y - 30 = 0$ divides the line segment joining points of $A(3, 4)$ and $B(7, 8)$.

- (A) $\frac{3}{2}$ (B) $\frac{5}{2}$ (C) $\frac{2}{5}$ (D) None of these

Q25. Find the co-ordinates of the in-centre of the triangle whose vertices are $(-36, 7)$, $(20, 7)$ and $(0, -8)$.

- (A) $(0, 1)$ (B) $(-1, 0)$ (C) $(1, 1)$ (D) None of these

Q26. The point whose abscissa is equal to its ordinate and which is equidistant from $A(-1, 0)$ and $B(0, 5)$ is:

- (A) $(1, 1)$ (B) $(2, 2)$ (C) $(-2, -2)$ (D) $(3, 3)$

Q27. In a right-angled $\triangle ABC$, D is the foot of the perpendicular from B on the hypotenuse AC . If $AB = 3 \text{ cm}$ and $BC = 4 \text{ cm}$, what is the area of $\triangle ABD$?

- (A) $\frac{54}{25} \text{ cm}^2$ (B) $\frac{25}{54} \text{ cm}^2$ (C) $\frac{24}{25} \text{ cm}^2$ (D) $\frac{54}{24} \text{ cm}^2$

Q28. In the adjoining figure, points A, B, C and D lie on a circle. $AD = 24$ and $BC = 12$. What is the ratio of the area of the triangle CBE to that of triangle AD

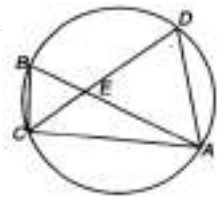

- (A) 1:5 (B) 1:4
(C) 1:3 (D) 1:2

Q29. The outer and inner diameters of a circular pipe are 6 cm and 4 cm respectively. If its length is 10 cm , then what is the total surface area in sq cm ?

- (A) $110\pi\text{ cm}^2$ (B) $101\pi\text{ cm}^2$
(C) $102\pi\text{ cm}^2$ (D) $103\pi\text{ cm}^2$

Q30. A right $\triangle ABC$ with sides 5 cm , 12 cm and 13 cm is revolved about the side 12 cm . What is the volume of the solid so obtained?

- (A) $100\pi\text{ cu cm}$ (B) $103\pi\text{ cu cm}$
(C) $102\pi\text{ cu cm}$ (D) None of these

Social Science (10 Marks)

Q31. Read the facts regarding the revolution of the liberals in Europe during 1848 and choose the correct option:

1. Abdication of the monarch
2. Universal male suffrage has been proclaimed
3. Political rights to women were given
4. Freedom of the press had been asked for

- (A) only 1 and 2 are correct (B) only 1,2 and 3 are correct
(C) only 1 and 4 are correct (D) only 1,2 and 4 are correct

Q32. Choose the correct chronological order for the following:

1. Jalianwala Bagh massacre
2. Rowlatt Act
3. Poona Pact
4. Lucknow Pact

- (A) 1,3,2,4 (B) 2,1,4,3 (C) 3,2,1,4 (D) 4,2,1,3

Q33. The purpose behind the painting “The Massacre at Chios” by Eugene Delacroix, 1824 was:

- (A) To appeal the emotions of the spectators and create sympathy for the Greeks
(B) To dramatize the incident in which twenty thousand Greeks were killed
(C) Focus on the suffering of women and children
(D) All of the above

Q34. Land that is left uncultivated for more than five agricultural years is called

_____.

- (A) Pasture land (B) Culturable waste land
(C) Barren land (D) Current fallow

Q35. You are a citizen of a country that has a democratic form of government. You want to ensure that the system of power sharing in your country is effective and that no one branch of government has absolute power.

- (A) All power is concentrated in the hands of Legislature only
(B) Power is divided between the central government and the states or provinces with each level having its own sphere of influence
(C) Power is separated among the legislature, executive and judicial branches with each branch having its own responsibilities and powers.
(D) Power is shared among different level of government such as National and local government with each level having some degree of autonomy

Q36. On the basis of ownership, industries are categorised as:

- (A) Large scale and small-scale industries
(B) Public sector, private sector, joint and Cooperative sector
(C) Basic/key and consumer industries
(D) Agro based and mineral based industries

Q37. Match the following

Column I

Column II

- | | |
|---------------------------------|---------------------|
| a. Balaghat mines | (p) Iron ore |
| b. Panchpatmali deposits | (q) Mica |
| c. Kudremukh mines | (r) Copper |
| d. Koderma mines | (s) Bauxite |

- (A) a-r,b-s,c-p,d-q (B) a-s,b-q,c-p,d-r
(C) a-q,b-r,c-s,c-p (D) a-r,b-s,c-q,d-p

Q38. Rita has taken a loan of 7 lakh from the bank to purchase a car. The annual interest rate on the loan is 14.5% and the loan is to be repaid in 3 years in monthly installments. The bank retained the papers of the new car as Collateral which will be returned to Rita only when she repays the entire loan with interest. Analyse the loan information given above and point out which one of the following is the correct option that describes the above statement accurately:

- (A) Mode of repayment (B) Terms of credit
(C) Interest on loan (D) Deposit criteria

Q39. A situation in which more persons are employed on a job than are optimally required.

- (A) Structural unemployment (B) Disguised unemployment
(C) Cyclical unemployment (D) Seasonal unemployment

Q40. Which one of the following is not true regarding the government order that makes it mandatory for an election candidate to declare his details in an affidavit?

- (A) It aims at reducing the influence of criminals in politics.
(B) It gives details of existing property and criminal cases pending against a candidate.
(C) It aims at reducing the influence of money in politics.
(D) The election commission checks these details and cancels the nomination papers of suspected criminals or if the information is false.

Science (20 Marks) Phy.+Chem. +Bio.

Physics (7 Marks)

Q41. N identical bulbs having their rating 220 V and 110 W are connected in parallel as shown in diagram. Now a fuse wire is connected in series of this system of bulb if current in fuse wire exceed from 10A it will burn, then maximum no. of bulb that can be connected so that the fuse wire not burn out:

- (A) 20 (B) 10
(C) 40 (D) 5

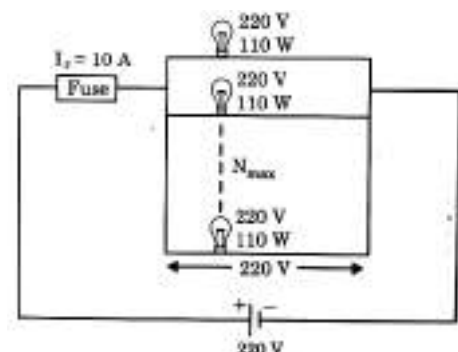

Q42. A proton accelerated by a potential difference 500 kV moves through a transverse magnetic field of 0.51 T as shown in figure. The angle θ through which the proton deviates from the initial direction of its motion is:

- (A) 15° (B) 30°
 (C) 45° (D) 60°

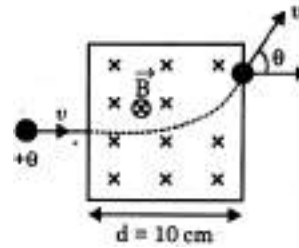

Q43. When the rectangular metal tank is filled to the top with an unknown liquid, as observer with eyes level with the top of the tank can just see the corner E; a ray that refracts towards the observer at the top surface of the liquid is shown. The refractive index of the liquid will be :

- (A) 1.25 (B) 1.41
 (C) 1.67 (D) 1.33

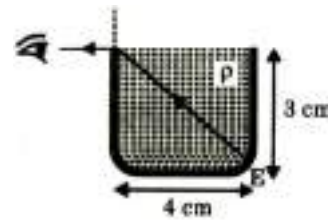

Q44. A ray incident at a point at an angle of incidence θ enters into a glass sphere placed in air which is reflected and refracted at the farther surface of the sphere as shown in the figure. The angle between reflected and refracted rays at this surface is 90° . If refractive index of the sphere is $\sqrt{3}$, the angle θ is :

- (A) $\frac{\pi}{3}$ (B) $\frac{\pi}{4}$
 (C) $\frac{\pi}{6}$ (D) $\frac{2\pi}{3}$

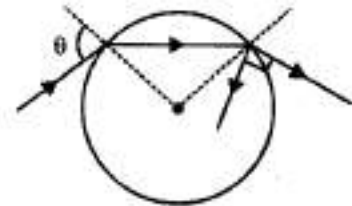

Q45. A magnetic field $\vec{B} = B_0 \hat{j}$ exists in the region $a < x < 2a$ and $\vec{B} = -B_0 \hat{j}$ in the region $2a < x < 3a$, where B_0 is a positive constant. A positive point charge moving with a velocity $\vec{v} = v_0 \hat{i}$ where v_0 is a positive constant, enters the magnetic field at $x = a$. The trajectory of the charge in this region can be like:

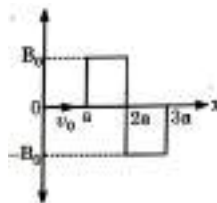

- (a) (b) (c) (d)

Q46. An object is placed at a distance 15 cm in front of a convex lens rays coming from object O after refraction from lens and then after reflection from mirror retrace its path, then distance d between lens and mirror will be

- (A) 40 cm (B) 20 cm
(C) 10 cm (D) 50 cm

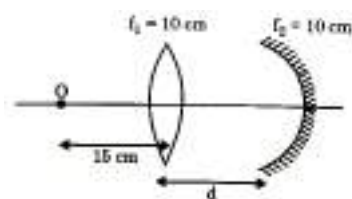

Q47. Equivalent resistance between A and B is

- (A) R (B) $\frac{3R}{4}$
(C) $\frac{R}{2}$ (D) 2R

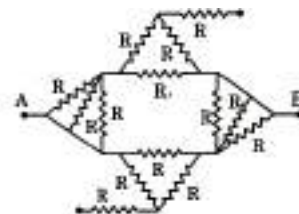

Chemistry (7 Marks)

Q48. 20 ml of 0.1 M H_2SO_4 solution is added to 30 mL of 0.2 M NH_4OH solution. The pH of the resultant mixture is [pK_b of $\text{NH}_4\text{OH} = 4.7$].

- (A) 9.4 (B) 5.0 (C) 9.0 (D) 5.2

Q49. What would be the equivalent weight of the reductant in the reaction

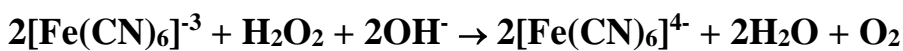

{Given :- Fe = 56 , C = 12, N = 14, O = 16, H = 1}

- (A) 17 (B) 212 (C) 34 (D) 32

Q50. The types of bond present in $\text{N}_2\text{O}_5(\text{g})$ are:

- (A) only covalent (B) only ionic
(C) ionic and covalent (D) covalent & co-ordinate

Q51. Arrange the following alkanols 1, 2 and 3 in order of their reactivity towards acid catalysed dehydration:

- (A) $1 > 2 > 3$ (B) $2 > 1 > 3$
(C) $2 > 3 > 1$ (D) $3 > 2 > 1$

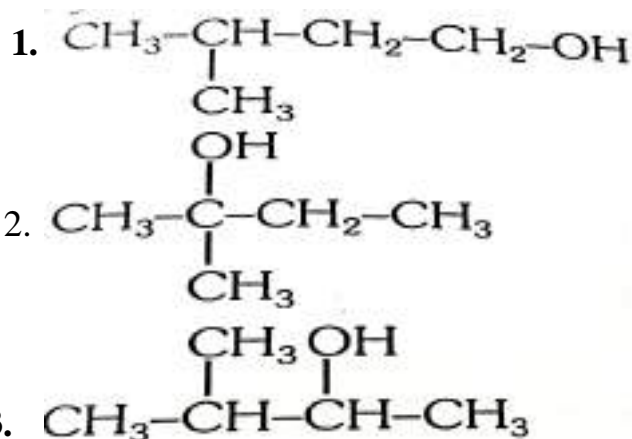

Q52. In the extraction of copper from copper pyrites, iron is removed as:

- (A) FeSO_4 (B) FeSiO_3 (C) Fe_3O_4 (D) Fe_2O_3

Q53. Correct IUPAC name of the given compound

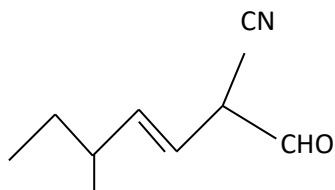

- (A) 2 – cyano – 5- methylhept – 3-enal
 (B) 2- Formyl – 5- methylhept – 3 –ene-1-nitrile
 (C) 5-Ethyl-2-cyano-hex-3-enal
 (D) 2-cyano-5-ethylhex-3-enal

Q54. Which of the following species has tetrahedral geometry?

- (A) BH_4^- (B) NH_2^- (C) CO_3^{2-} (D) H_3O^+

Biology (6 Marks)

Q55. Which of the following statements is false?

- (A) Angiotensin II being a powerful vasoconstrictor, increases glomerular pressure and thereby GFR.
 (B) Angiotensin II activates the adrenal cortex to release aldosterone.
 (C) Aldosterone promotes reabsorption of Na^+ and water from the DCT and CT leading to an increase in B.P. and GFR.
 (D) ANF causes vasoconstriction.

Q56. I. 'Y' hormone induces flowering in mango and also promotes rapid internode / petiole elongation in deep water rice plants and hence helping leaves or upper part of shoot above water.

II. 'X' hormone promotes root growth and root hair formation.

III. 'Z' hormone inhibits the seed germination, increases the tolerance of plant to various stresses, play important role in seed development, maturation and dormancy.

Identify the correct names of hormones:

- (A) Y = ABA; X = Auxin; Z = GA (B) Z = GA; X = Auxin; Y = C_2H_4
 (C) Y = Auxin; X = C_2H_4 ; Z = GA (D) Y = C_2H_4 ; X = Auxin ; Z = ABA

Q57. Choose the correct statement:

- (A) Electrical synapses are more common in our neural system than chemical synapses.
- (B) The new potential in postsynaptic neuron may be either excitatory or inhibitory.
- (C) Hypothalamus is the major coordination centre for sensory and motor signaling.
- (D) The tracts of nerve fibres that connect two cerebral hemispheres are called corpora bigemina.

Q58. Given below is a statement with some blanks. Fill up the blanks correctly:

The male reproductive system consists of two testis. Each testis contains thin folded tubes called the A in which meiosis takes place to produce the male gametes, the sperms. These sperms move to the B (a highly coiled tube formed from the merging of the seminiferous tubules), and then to the C . The two vasa deferentia merge to form the urethra, which travels to the outside of the body through the penis. The cells located between the seminiferous tubules are called D cells and they are responsible for the formation of the male hormone E .

- (A) A - seminiferous tubules; B - epididymis; C - vas deferens; D - interstitial cells; E – testosterone
- (B) A - seminiferous tubules; B- epididymis; C - urethra; D - interstitial cells; E - testosterone
- (C) A - seminiferous tubules; B - epididymis; C - vas deferens; D - interstitial cells; E - progesterone
- (D) A- uriniferous tubules; B - epididymis; C - vas deferens; D - interstitial cells; E – testosterone

Q59. Which of the following is not correct ?

- (A) As the seed matures, its water content is reduced and seeds become relatively dry (10-15% moisture by mass).
- (B) The seed dormancy is the internal or innate inhibition of generation of normal or viable seeds.
- (C) Embryo in dormant seed shows higher rate of general metabolic rate.
- (D) Because of dormancy, seeds remain viable for longer period and can be stored.

Q60. The allele for red flower colour (R) in a certain plant is co-dominant with the allele for white flowers (R'). Thus, a plant with the genotype RR' has pink flowers. Tall (D) is dominant to dwarf (d). What would be the expected phenotypic ratio from a cross of RR' dd plants with R'R'Dd plants?

- (A) 9 : 3 : 3 : 1
- (B) 50% pink, 50% white, and all tall
- (C) 1 : 1 : 1 : 1, in which 50% are tall, 50% dwarf, 50% pink and 50% white
- (D) 3 : 1

SPACE FOR ROUGH WORK



RPS GROUP OF SCHOOLS

Under the aegis of RPS Education Society, M/Garh

MARCHING PROUDLY FROM CLASSROOMS TO THE WORLD STAGE.

ODISSI DANCE SCHOLARSHIP

CTSSS
CBSE CLASS-X
99%



AMISHI GAUTAM
D/o Mr. SAPNA GAUTAM & Mr. ANIRAD GAUTAM

*Limitless Minds,
Unstoppable Spirit!*

CUET -2025
AIR-3

Marks
1205
1250

PURVA SINGH
D/o Ms. BHAWNA & Mr. KULDEEP SINGH

Selected in **TEAM INDIA** for **IISD-2025** to be held at **SOCHI, RUSSIA**

UNIVERSITY OF SOUTHAMPTON, ENGLAND

ISI
(INDIAN STATISTICAL INSTITUTE, KOLKATA)

CBSE CLASS XII TOPPERS
99% OF BOYS **99%** OF GIRLS

CBSE CLASS X TOPPER
99.6% PERCENT

JUNIOR & YOUTH NATIONAL PARA BADMINTON CHAMPIONSHIP 2025

5 GOLD MEDALS

AIR 2

AADISH JAIN D/o Mr. DEEPTIKA JAIN & Mr. GOURLY JAIN

GAURAV DEWAN S/o Mr. ANILK DEWAN & Mr. FASHION DEWAN

ISHAN AFRIA S/o Mr. SANTOSH & Mr. VARENDER KUMAR

ANUSHKA ROY D/o Mr. NEENA CHAUDHARY & Mr. SANJAY ROY

PARV S/o Mr. DEEPIKA & Mr. NAVNEET

DHRUV SINGH ROHA S/o Mr. ANSHU & Mr. VIRENDER SINGH ROHA

KARTIK SUHAG S/o Mr. SARDI & Mr. SATISH KUMAR

ROAD TO SRCC

PURVA SINGH D/o Ms. BHAWNA & Mr. KULDEEP SINGH SRCC, DELHI

VAISHNAVI PANDEY D/o Ms. PUSHPA TIWARI & Mr. RAJAWATIKA N. P. SRCC, DELHI

HARISH KUMAR S/o Mr. NELLAN PADAV & Mr. ASHOK KUMAR SRCC, DELHI

RIDDHIMA D/o Ms. RUPIN & Mr. RAJENDRA SRCC, DELHI

DAKSHU S/o Ms. BEKA DEVI & Mr. DINESH KUMAR SRCC, DELHI

NAHNU DEV S/o Ms. SARDI & Mr. DHARMENDER SRCC, DELHI

HARSHITA YADAV D/o Ms. KUSUM YADAV & Mr. KULDEEP SINGH SRCC, DELHI

SUPER ACHIEVEMENTS:

SHAPING CHAMPIONS WITH A 360° VISION

107 STUDENTS Above 500 Marks **NEET** (Qualifiers)

55 STUDENTS Above 99%ile **JEE Main** (Qualifiers)

96 STUDENTS **JEE Advanced** (Qualifiers)

145 STUDENTS **NDA** Written Qualifiers

59 STUDENTS **CLAT** (Qualifiers)

155+ STUDENTS 95% & Above **CBSE CLASS-XII**

435+ STUDENTS 95% & Above **CBSE CLASS-X**

ADMISSIONS OPEN SESSION 2026-27

RPS TAKES THE GLOBAL LEAP WITH THE INTERNATIONAL BOARD FROM SESSION 2026-27

Our Campuses: Mahendergarh | Rewari | Rewari City | Dharuhera | Kosli | Behror | Hansi | Narnaul | Hisar | Karnal | Rohtak | Dadri | Gurugram Sec- 50 | Gurugram Sec- 89 | Rosewood City, Gurugram | Kanina | RPSIS Dharuhera

Web: www.rpsgroup.edu.in

Top-Notch Hostel Accommodation for Boys and Girls at M/GARH, KANINA, BEHROR, KOSLI & HANSI CAMPUSES